

~~~~~

# Topline

**ULTRA VIOLET TREATMENT SYSTEM**





Topline 9907 Rev 0  
01-07-05

### **Topline Electronics Ltd Introduction**

Topline were established in 1986 to provide high quality equipment. Topline now provide integrated dosing equipment packages with a comprehensive service backup. We believe that our after sales service is an integral part of the company's success, and wish to assure existing and new customers that we will continually review product and service performance with the aim of improving both.

If you are experiencing any problems with your UV system or general water quality please do not hesitate to contact a Topline engineer on 01323-440760.

Topline are always willing to develop new products and services with clients, so if you have an idea on how to improve any of Toplines products or wish to develop a product for your own use please contact Andrew Hunt on 01323 440760.

### **Product Introduction**

The system supplied can treat up to 400m<sup>3</sup> per hour dependant on how many UV tubes are installed. Each of the tubes treats 25m<sup>3</sup> per hour. The tubes are configured in banks of 4, 6 and 8.

Each bank of 4 tubes is controlled by one controller. The controller has UV status lights on the side. These lights are on when the corresponding tube is on.

The system which is virtually maintenance free, does however require a 12 month service. This service is essential to maintain the units efficiency. If the unit is not serviced the water will not be effectively treated with UV light.

During the service the UV tubes, quartz outer sleeves and seal kits should be replaced. The strainer cartridge should also be removed and checked for damage and cleaned.

Topline 9907 Rev 0  
01-07-05

**Technical Data UV System**

**Treatment rate (Each Tube)**

Pool volume 25m<sup>3</sup> per hour

**Power Requirement**

240 VAC single phase 50 Hz.

**Power Consumption**

300-600 watts

**Operating Temperature**

0 - 50 degrees centigrade

**Enclosure**

316 Stainless Steel

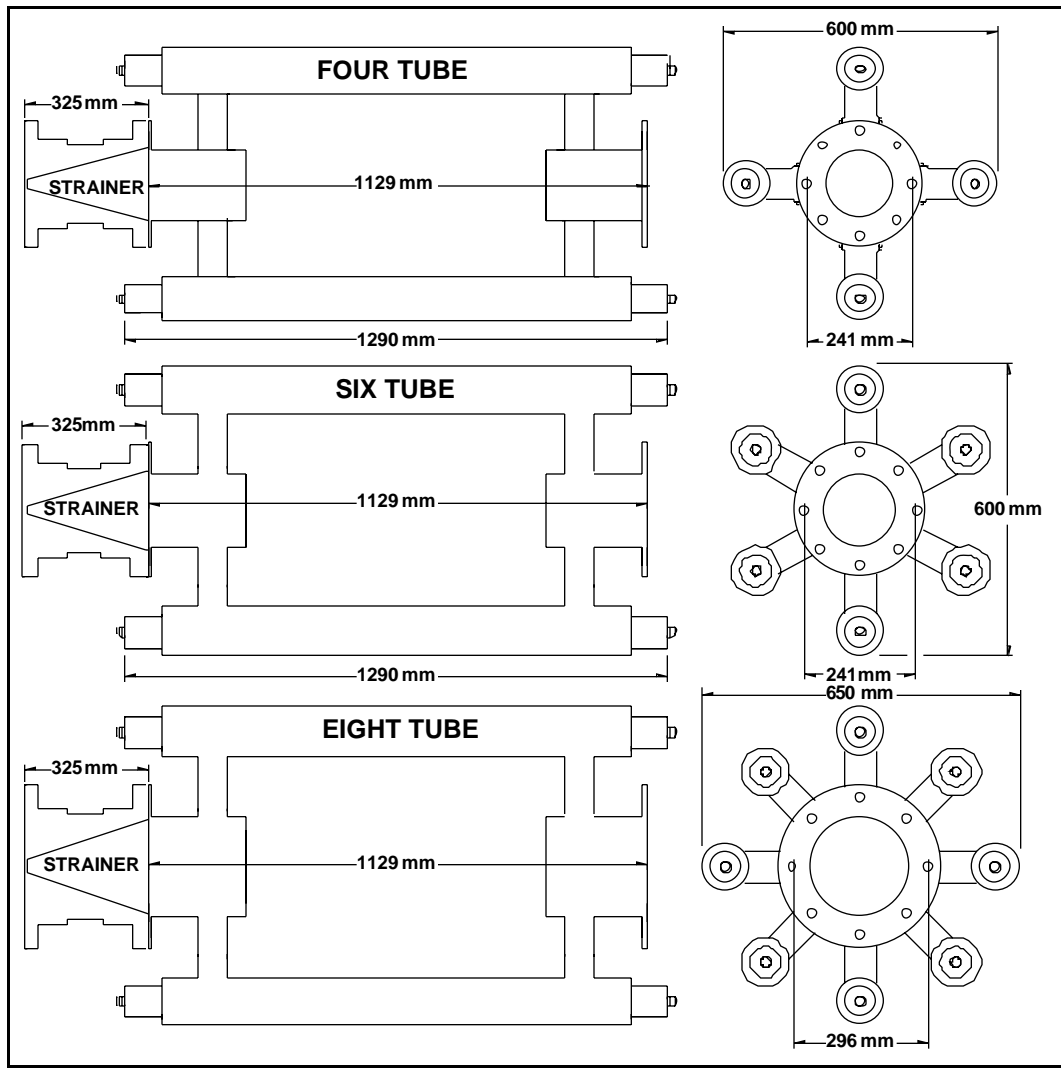

Topline 9907 Rev 0  
01-07-05

**CE Certificate Declaration of conformance**

Manufacturer's Name        Topline Electronics Ltd  
Manufacturer's Address     Unit 7, Crown Close  
                                     Hailsham, E.Sussex  
                                     England, BN27 3JF

Declares that the above product conforms to the following product specifications:

**Low Voltage Directive 72/73 EEC**

**Electromagnetic Compatibility Directive 2004/108/EC**

**Restriction of Hazardous Substances (RoSH)  
Directive 2002/96/EC**

**Waste Electrical and Electronic Equipment (WEEE)  
Directive 2002/95/EC**

CE marking.

I the undersigned, declare that the equipment above conforms to the above directives and carries the CE marking.

Manufacturer Topline Electronics Ltd

Signature on behalf of Topline Electronics Ltd *A. Hunt*

Date Feb.10th 2007

Topline 9907 Rev 0  
01-07-05

**Installation Instructions**

**Control System Power Requirements**

Only qualified and competent electricians working to the 16th Edition of Electrical Regulations should install electrical equipment.

The controller is powered by a **240 volt AC single phase** supply. A local isolator should be fitted adjacent to the control unit. The supply should be taken from a ring main and must be run in suitable conduit terminated with suitable glands. Cable entry should be made into the bottom of the enclosure. All mains wire conductor size used should be 1mm max. The incoming AC supply must be via a 3 amp fused local isolator.

The unit is protected by an internal RCBO (See graphic below). The mains supply needs to be interlocked to the circulation system, so that in the event of the circulation system failing, the power to the UV will be cut.

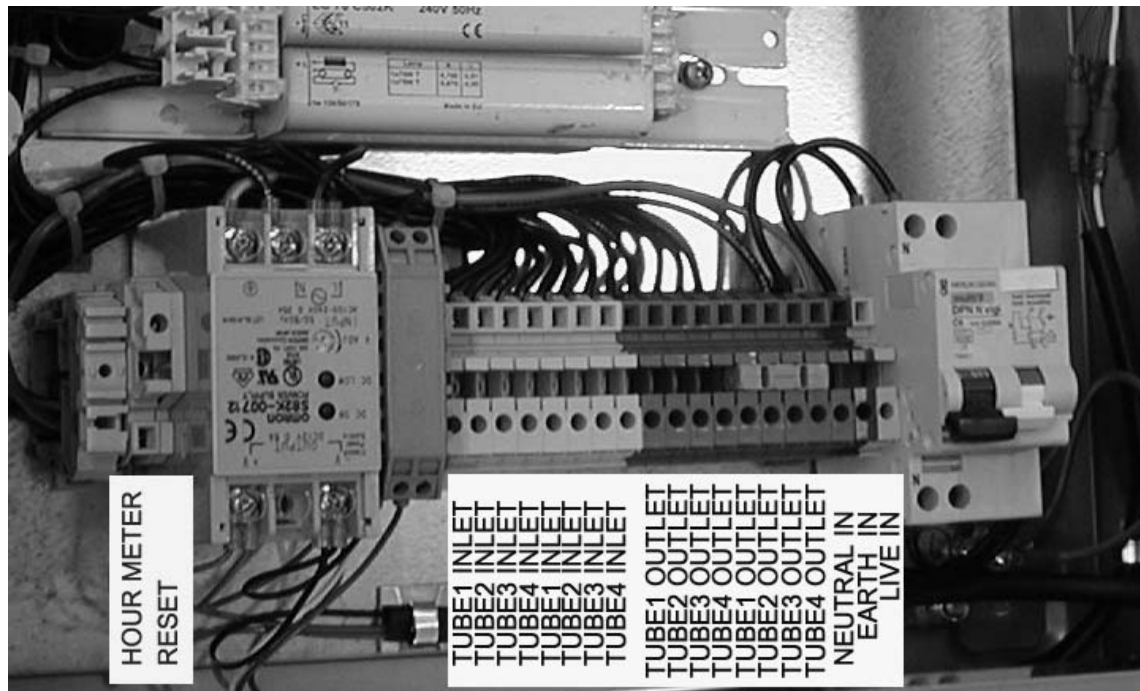

Topline 9907 Rev 0  
01-07-05

**Installation Instructions (Cont)**

**Position of UV**

The UV system should be installed to take the full flow of the pool system post filter, the connection being made via isolation valves so that the UV unit can be serviced. When the isolation valves are closed the pool water should continue to circulate via the bypass pipe work. The UV system is manufactured from 316 stainless steel so weight should be kept in mind when installing the equipment.

Provision should be made for the withdrawal of the UV and quartz tubes from the ends of the stainless steel sleeves.

Note the direction of flow through the UV, the inlet and outlet is identified on each stainless steel outer tube.

The strainer cartridge should be positioned down stream of the UV system as close as possible to the UV system.

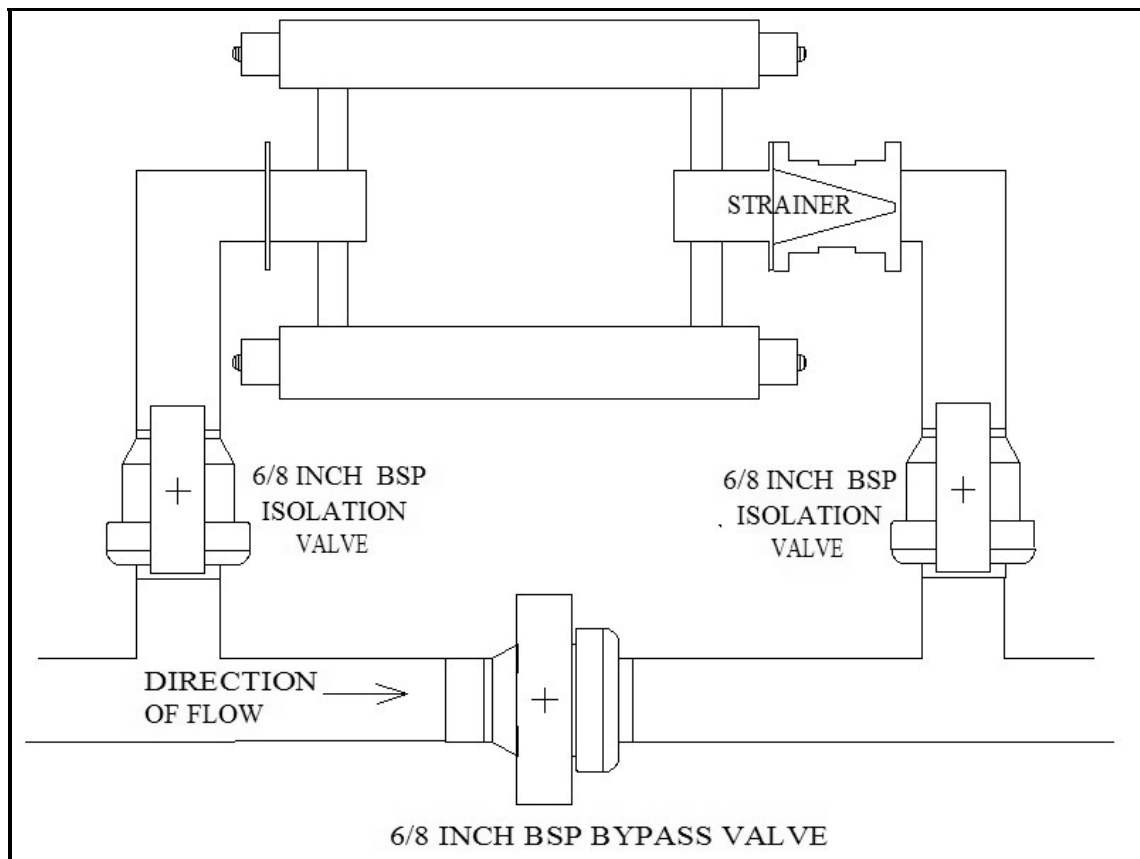

Topline 9907 Rev 0

01-07-05

**Installation Instructions (Cont)**  
**Position of UV in circulation system**

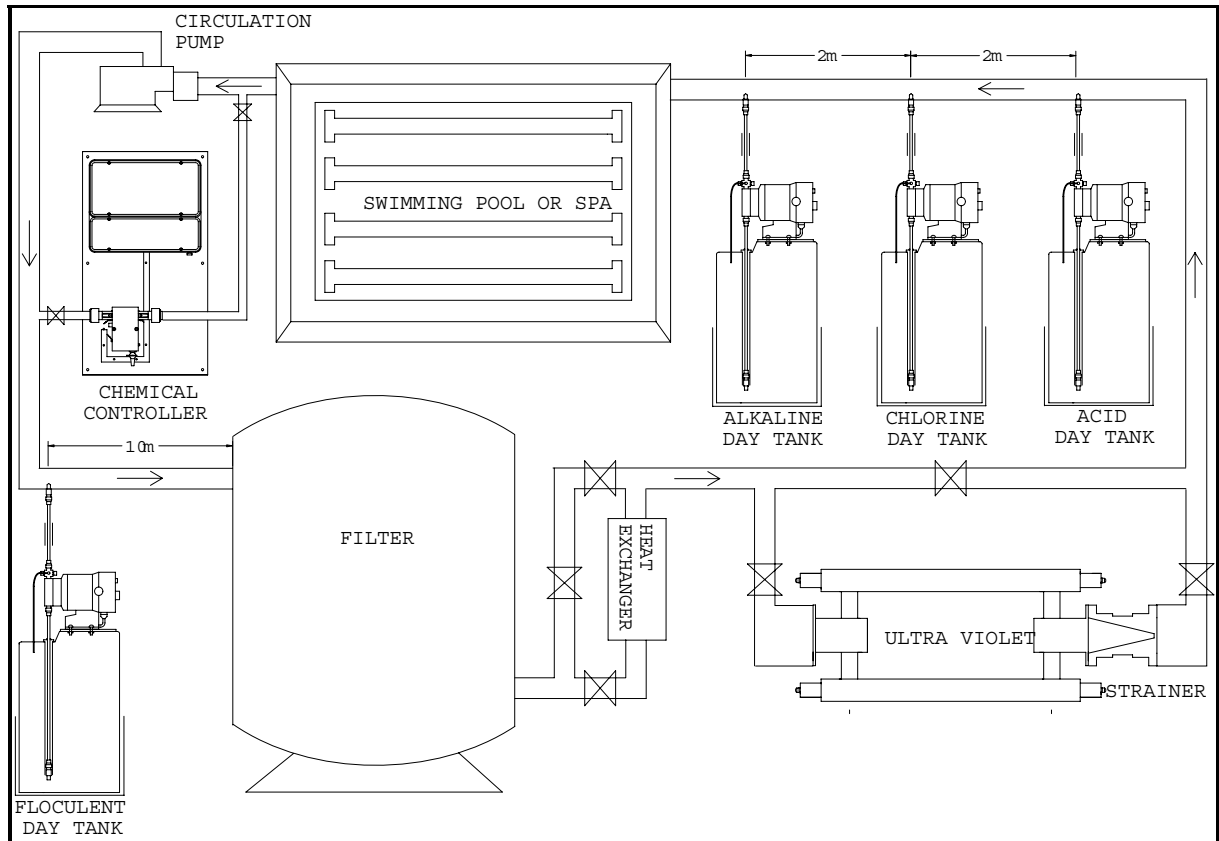



Topline 9907 Rev 0  
01-07-05

**Installation Instructions (Cont)**  
**Electrical Connections to UV Tubes**

Electrical connections are made at each end of the UV tube via a standard push on connector (supplied) and in the control unit via screw terminal din connectors.  
The connections are identified on the graphic which is below.

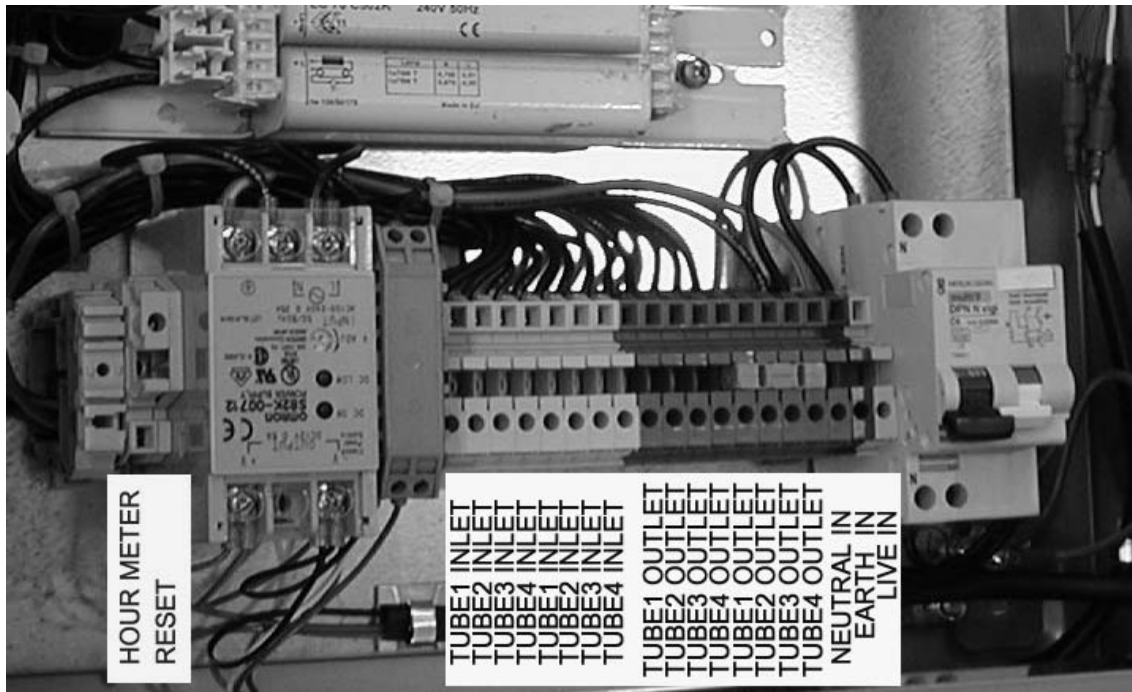

Each UV sleeve should be earthed at the point indicated in the below photograph.  
There is an earth point on all UV sleeves.



Topline 9907 Rev 0  
01-07-05

### **Commissioning**

#### **Installing quartz tubes and leak testing**

Insert the quartz tubes as shown in the below photographs.

Before inserting UV tubes the unit needs to be checked for leaks. Allow water to flow through the assembly by leaving open the by pass valve, opening the outlet valve and then slowly opening the inlet valve. Check for leaks. Close the bypass valve and recheck for leaks. If there are any leaks around the quartz tubes – tighten the inner cover carefully. If the leak does not stop after slight movement of the inner ring, check for damage to the ‘O’ rings, quartz tube or stainless steel assembly. If no damage is found clean and reassemble. Repeat leak testing.

Once the leak test is complete, isolate from pool and insert the UV tubes and make electrical connections. To power up the UV system, open the outlet valve followed by the inlet valve and then close the bypass valve. Check for leaks. Power up the UV control via local isolator.

### **Commissioning**

#### **Installing quartz and UV tubes**

**Care should be taken when installing the quartz tube, due to its fragile structure.**



Insert the quartz tubes into the outer tubes. Tighten inner cover ( **Hand tight only** ).  
Slide ‘O’ ring over quartz tube.  
Silicone grease ‘O’ ring (RS494-124 supplied ).  
Wrap two wipes of PTFE tape on Inner  
Cover thread.



Insert UV tube



Attach connector.

Topline 9907 Rev 0  
01-07-05

**Commissioning**  
**Installing quartz and UV tubes (Cont)**



Attach outer cover.



Use flexi conduit (supplied) to control unit.



Topline 9907 Rev 0  
01-07-05

**Commissioning Sheet**  
**REMOVE THIS PAGE AT COMMISSIONING**

**Commissioning procedure**

It is important that the commissioning is comprehensive and complete leaving no grey areas of responsibility or accountability.

Clarity of description and explanation of the equipment to the client is therefore vital. Before the UV system is explained, complete the below check list. All the lines must be completed, **no blank lines** are to be left. If any item is **not OK** then an **explanation** must be given.

**Commissioning Check list**

1. Position of system |\_\_\_\_\_|
2. Leaks |\_\_\_\_\_|
3. Flow |\_\_\_\_\_|
4. Electrical RCCB |\_\_\_\_\_|
5. Electric flow cut off |\_\_\_\_\_|
6. Unit labels |\_\_\_\_\_|
7. Access to tubes for  
Fitting or changing |\_\_\_\_\_|

Notes reference above numbers

---

---

---

---

---

---

---

---

---

---

Topline 9907 Rev 0

01-07-05

**ACCEPTANCE of EQUIPMENT**

**THE HANDOVER PROCEDURE, COMMISSIONING SHEET AND THIS SHEET ARE TO BE REMOVED AND RETURNED TO TOPLINE OR COMMISSIONING AGENT**

**No person** should sign this commissioning sheet unless they are **completely satisfied** with the UV system supplied. Signing of this commissioning sheet means that you **accept** the equipment and have understood its operation, Risk Assessment and Operations Manual. **The UV system is now yours and you are responsible for its maintenance and operation. No person should operate the equipment unless they have attended the training session.**

Start time ..... Finish time .....

Site .....

Address .....

.....

.....

Client (site) representative .....

Telephone .....

Fax .....

Commissioned by .....

Date .....

Topline 9907 Rev 0  
01-07-05

### **Operation**

There are no routine operations required on the UV system. If the unit develops any leaks, open bypass valve and close the inlet and outlet valves and call Topline or your installer. The system will need servicing every 12 months or when the hour meter shows 8760.

### **Maintenance**

The system will need servicing every 12 months by an approved company or when the hour meter shows 8760. The hour meter should be reset to zero after servicing (To reset contact Topline). As part of the service, the quartz tube, UV tube and 'O' rings (for quartz and stainless tubes) should be replaced. The strainer should also be checked every 12 months or if circulation flow rate is noticeably low (higher than normal pressure on the outlet of the sand filter). All parts for a service are available in a kit from Topline Electronics Ltd, telephone 01323-440760.

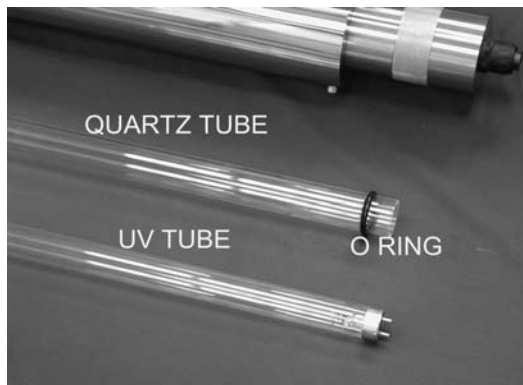

Replace all of above every 12 months.  
All tubes both ends.



Grease 'O' rings after reassembly.

## **Risk Assessment**

**If the equipment is not operated by persons who are proficient in the operation of swimming pool plant, then there is a risk of:**

- 1. Reduced circulation rate.**
- 2. The use of a UV system does not remove the need for continued testing of the water by an independent authority. Testing should be carried out as outlined by PWTAG and detailed in Health and Safety in Swimming Pools. If more details are required on these publications contact Topline on 01323 440760.**
- 3. Care should be taken not to look at the Ultra Violet light source as this could damage your eyes. If you do come into contact with UV light seek medical advice.**
- 4. Heat is generated within the control unit. Attached the control unit is a heat label. When this label is red the case is above 50 degrees c.**